

# Correct Document Size

## File Document Size

LANDSCAPE – document size MUST be **91mm x 60mm**

PORTRAIT – document size MUST be **60mm x 91mm**

### TIPS:

1. Avoid designing borders close to the trimmed edge
2. Signature panels can be any size as long as they are square or rectangle in shape. No rounded corners or text on the signature panel are allowed

## Front of card

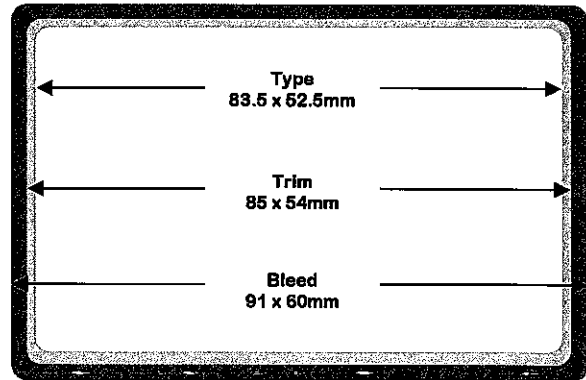

Measurements are in mm

## Back of card

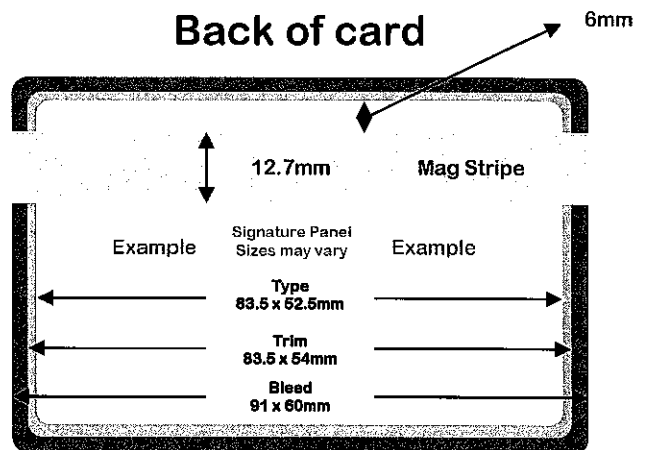

Measurements are in mm

## Smart Card Chip

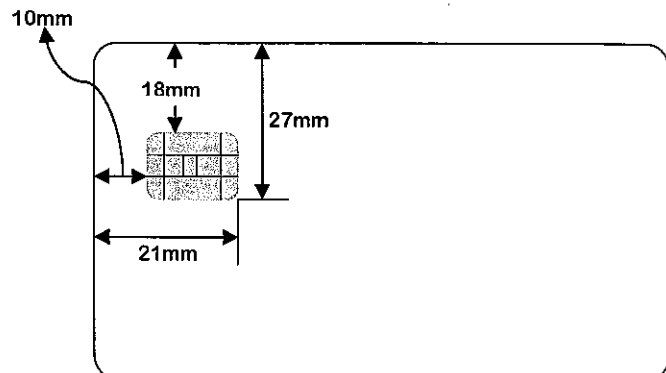

# Correct Document Size

## Accepted software formats (PC Compatible Files only)

**Adobe Illustrator- Ai & EPS** convert fonts to outlines unless the artwork department is required to make changes

**Adobe Photoshop- PSD & EPS** this file type is not recommended for files including text as it diminishes the quality when printed

**PDF-** high resolution, embed all included fonts

Include all embedded and placed files. For more information on file formats contact PPC artwork department.

## Colours for printing

Files will be accepted in CMYK and Pantone colours only. Files in RGB will not be accepted

**Pantone Colours.** Ensure your artwork files specify the exact pantone colour names within the file. All pantones must also be included on your order form.

## Images

**Photographs** must be a minimum of 300dpi (resolution) at 100%. NOTE: If photos are opened in other programs and are enlarged the resolution needs to be higher than 300dpi.

**Vector Art** must remain as editable paths for optimal printing standards.

## Fonts

All fonts used in the file must be supplied if outlines have not been created. Fonts must be scripted in True Type Format (windows) or Post Script (windows)

## Gradients & Vignettes

Ensure gradients created in Illustrator are set at 2400dpi in attributes and document setup. To prevent banding it is best to create gradients in Photoshop.

Also, due to the uniqueness of printing on plastic, graduations should not be 0% to 100%. If graduations are created at about 6% to 99% they have a less tendency of banding.

## Logos

It is preferable if any logos be supplied as vector drawn images, not bitmap or raster. This ensures the image remains crisp and clear. Whilst not preferred, a high quality bitmap or raster logo can be used.

## General Requirements

**Frames/borders** must not be used to mark the trim if you do not want them to be printed.